

CLEVELAND ELECTRIC LABORATORIES

Fiber Optic Sensing Solutions



LCM-200 Series Brainy Bolts

The integrity of a structure may critically depend on proper installation and continued proper tensioning of the fasteners used to join the components of the structure. Improper tensioning of a fastener during installation, subsequent extreme loading, vibration, corrosion or severe environments can cause a fastener to yield, potentially leading to structural failure. Maintaining appropriate tension in fasteners may be a vitally important factor in maintaining the integrity of a structure.

Brainy Bolts, developed and patented by Cleveland Electric Laboratories (CEL), are part of the FiberStrike® family of innovative sensing solutions. Brainy Bolts utilize state of the art fiber optic technology to measure tension in fasteners. A Brainy Bolt insert may be integrated into virtually any bolt, rivet, stud or screw having a body diameter of 0.5" or greater, making it a smart fastener and allowing measurement of tension in any location including those that are remote or difficult to access. Fiber optics are inherently immune to electromagnetic and radio frequency interference, lightning and corrosion. Brainy Bolts contain no electronic components, require no electrical power, and emit no signals, making them an excellent choice for long term, real-time structural monitoring applications in both benign and hazardous environments.

PRINCIPLE OF OPERATION

A Brainy Bolt contains a fiber sensor known as a Fiber Bragg Grating (FBG). Light is fed into the fiber, and the FBG reflects light of one given wavelength back to an optical interrogator. If the tension on the optical fiber changes, the reflected wavelength of light correspondingly changes; any change is detected by the optical interrogator and then converted into a tension measurement. All Brainy Bolts also provide individual temperature compensation capability using the same internal fiber and optical interrogation methodology.

- Brainy Bolt inserts are delivered with the internal FBG slightly pre-tensioned and pre-calibrated to reflect at a specific wavelength.
- FBGs can be individually tuned, each to a unique wavelength, so each sensor may be given its own address; this allows multiple FBGs, each individually addressable, to be arrayed on a single fiber.
- Multiple FBGs on one fiber allows many Brainy Bolts or other fiber sensors to be networked with minimal fiber optic cabling.
- Brainy Bolts are equipped with a pre-installed armored optical fiber pigtail that is spliced into single-mode 1550nm fiber leading to the optical interrogator; the pigtail is available in various lengths.
- Many Brainy Bolts can be simultaneously monitored in real-time by the optical interrogator.
- The optical interrogator may be located at distances up to 25+ km from sensors.



MODIFICATION OF FASTENER TO ACCEPT BRAINY BOLT

A structural fastener in which tension is to be monitored is modified to accept a Brainy Bolt insert by boring and threading the fastener according to specific machining dimensions. An example of modification dimensions to accept a Brainy Bolt insert having a body length of 1.25 inch is shown in Figure 1. Modification dimensions to accept Brainy Bolts having other body lengths will be provided by CEL-ATG as required. A fastener modified to accept a Brainy Bolt should have a body diameter no less than 0.5" and a shank length such that the bottom of the Brainy Bolt insert terminates above the threads of the fastener.

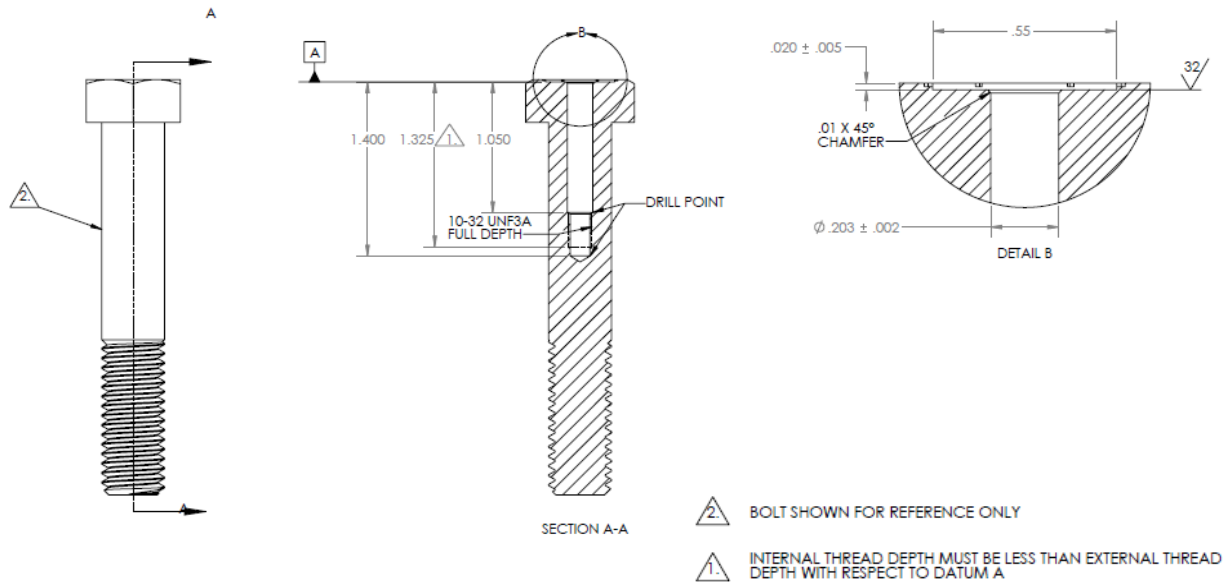

Figure 1. Dimensions of fastener modification to accept Brainy Bolt insert. (Generic bolt shown.)

Engineering analyses performed by CEL show that this modification has no effect on the ultimate tensile strength of a structural fastener of any alloy that has a diameter of at least 0.5 inch (although stiffness is reduced); there is a small effect on shear strength, but this effect becomes negligible in fasteners of larger diameter. It is the responsibility of the fastener certifying authority to determine the proper size fastener for the application and to determine that the fastener retains adequate strength for its application after modification. CEL can modify fasteners to the certifying authority's specifications to accept Brainy Bolt inserts. CEL also can provide Brainy Bolt inserts and instructions for fastener modification to the integrator.

INSTALLATION OF BRAINY BOLT IN MODIFIED FASTENER

Brainy Bolt inserts monitor the tensile load on a fastener by measuring the elongation of that fastener, but Brainy Bolt inserts are neither designed nor intended to bear any of the tensile load on the fastener. Accordingly, proper torque on a Brainy Bolt insert is essential when integrating it into a structural fastener. The head of a Brainy Bolt is a "tamper-resistant" configuration, and a special tool, part number LCM-255 available from CEL, is required to properly engage the head on the insert. Only this tool (shown to the right), and a 1/4" drive torque wrench adjustable in inch-pounds, should be used to install a Brainy Bolt insert. No other tool(s) should be used for this purpose. CEL will specify the proper torque value to use for any installation.



From small industrial to large structural applications, Brainy Bolt inserts can be integrated into many fastener types to enable real-time measurements and structural monitoring not previously possible. Brainy Bolts are one example of the many innovative FiberStrike sensors offered by Cleveland Electric Laboratories to help you solve your monitoring problems. We invite your inquiries.